

TECHNICAL BULLETIN - #9708
SUBJECT: #1015 STROBE RETROFIT KIT

Effective Date: 8/11/97

Revised 3/15/05

#1015 STROBE RETROFIT KIT

1. Remove cover from stop arm base.
2. All bases manufactured by SMC are equipped with strobe power pack mounting holes. Install power pack using four (4) #8 x 1/2" sheet metal screws. Make sure power pack inputs are facing hinge pivot. (see figure 1)

Note: Back of Power Pack should contact metal for heat dissipation.

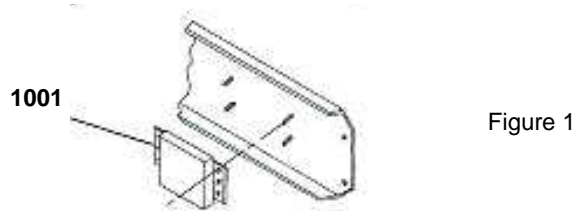

3. Install flashtubes on stop signs as shown in figure 2.

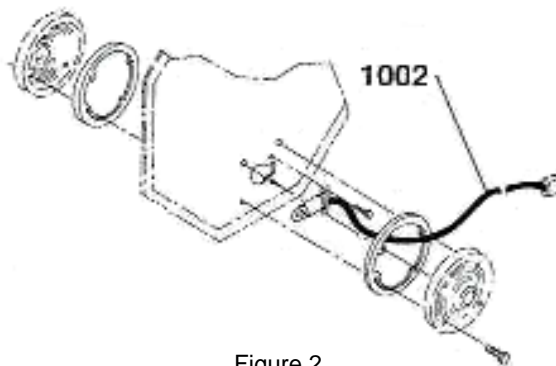

4. Route flashtube leads through stop arm base as shown in figure 3. Next, wire flashtube leads into plastic plugs as shown in figure 4. Finally, plug flashtube leads into the two lamp receptacles on power pack.

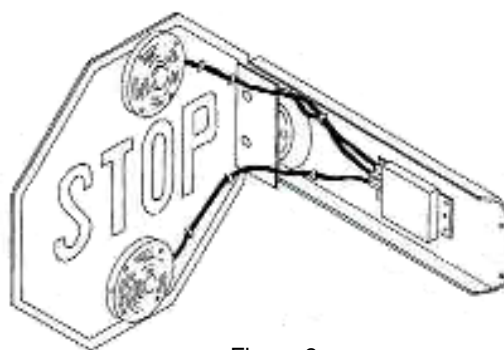

TECHNICAL BULLETIN - #9708
SUBJECT: #1015 STROBE RETROFIT KIT

Effective Date: 8/11/97

Revised 3/15/05

FLASH TUBE ASSEMBLY INSTRUCTIONS

1. Place black boot (included) over red cable
2. Plug wire leads into appropriate socket holes as indicated in the figure below
3. Slide the black boot onto the plastic socket, making sure the wire leads are not visible
4. Install flash tube in:

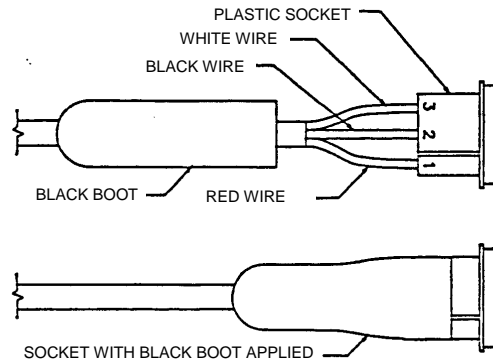

Figure 4

5. Follow wiring schematic shown in figure 5 to ensure proper operation of unit.
Note: Unit is polarity protected so that improper connection will not damage the unit.

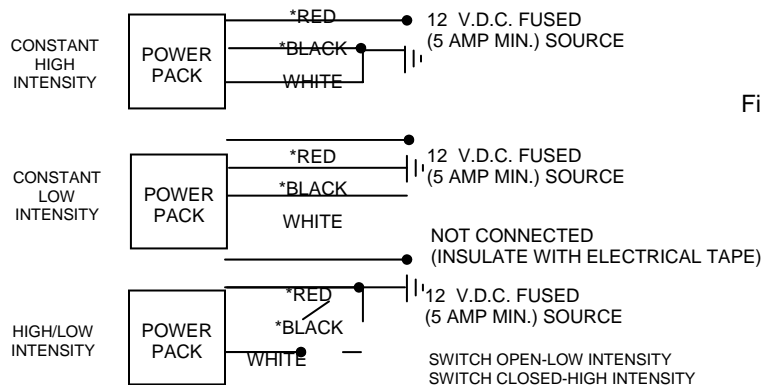

Figure 5

*ON/OFF SWITCH MUST BE USED WITH RED OR BLACK WIRE

6. Correctly installed power pack should resemble figure 3
7. Replace cover and reseal with silicone

***Low Voltage conditions:** In cold weather and utilizing the 8-way control box [Weldon or In-power] as a power source may result in a low voltage input condition to the unit. (*the power source originates from the 'STOP ARM SOLENOID' terminal*)

1. Check input voltage at the power pack. This should measure > 12 Volts. Preferably 12.8V. (This is the red wire to the blade fuse on the outside of the black plastic power pack box.)
 - If the input voltage is > 12V, then the power pack is most likely defective. It needs to be replaced.
 - If the input voltage is < 12 Volts, then it's recommended adding a relay and rewiring. Refer to Tech bulletin A001 to bring the battery in as the power source (when the 8-way system is invoked). This greatly improves the power source capability.

**WARNING!! Do NOT measure OUTPUT voltage to Xenon bulbs!
It is high voltage and could cause injury!**