

360° LED BEACON 848 SERIES

Specialty Manufacturing's 848 Series of LED Beacons (Strobes) are designed to meet **SAE J845 Class II Specifications**.

- 360° Visibility
- Voltage: 12VDC
- Mounting: 4 bolt flange mount
- Lens Height: Available in 2" Nominal Height

WARNING

1. Do not install or operate the product until reading and understanding these safety considerations.
2. Unplug and remove the power pack that may have been used with an older flashtube strobe before installing this LED strobe light. Use the provided adapter cable to bridge the connection from the removed power supply.
3. Failure to follow precautions and instructions could result in damage to the product, vehicle or installer.

Remember:

- When installing the product, always wear proper safety equipment and use proper tools.
- Exercise caution when working with live electrical connections.
- When drilling into any vehicle surface, ensure that the area is free from electrical wires or fuel lines which could be damaged.
- Verify all of the federal, state and/ or local requirements pertaining to Strobe Lights or Warning Beacons for proper location prior to mounting.
- Do not stare directly into the light as momentary blindness and eye damage could result
- Do not touch the lens surface of the product immediately after running as it may be is hot.

PERMANENT MOUNTING

1. Select the desired location on the vehicle.
2. Place the mounting gasket in the desired location.
3. Mark the location of the (4) four mounting holes on the surface (View A).
4. If running the wires through the mounting surface, mark the location of the center hole.
5. Remove the gasket and drill the holes with a 11/64" drill.
6. If needed, drill the center hole with a 5/8" hole saw.
7. Ensure that the mounting area is free of any contaminants or burrs.
8. Connect the power wires of the vehicle to the product with the provided connectors (View B)
9. Test product prior to final mounting.
10. Secure product with mounting hardware (View C).

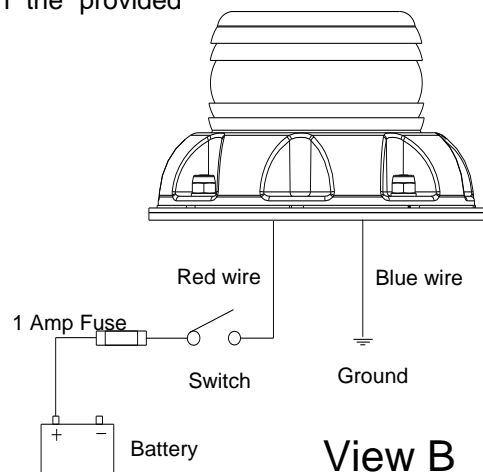
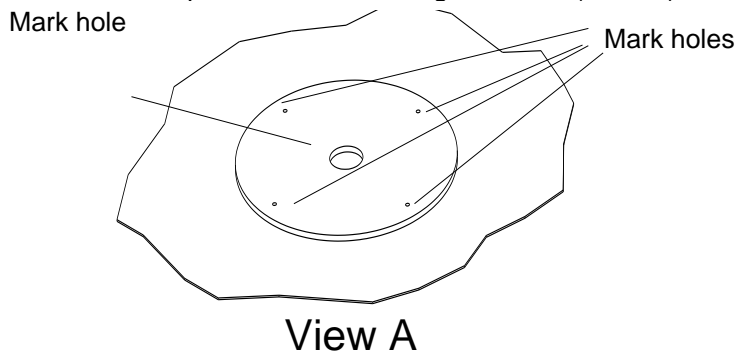

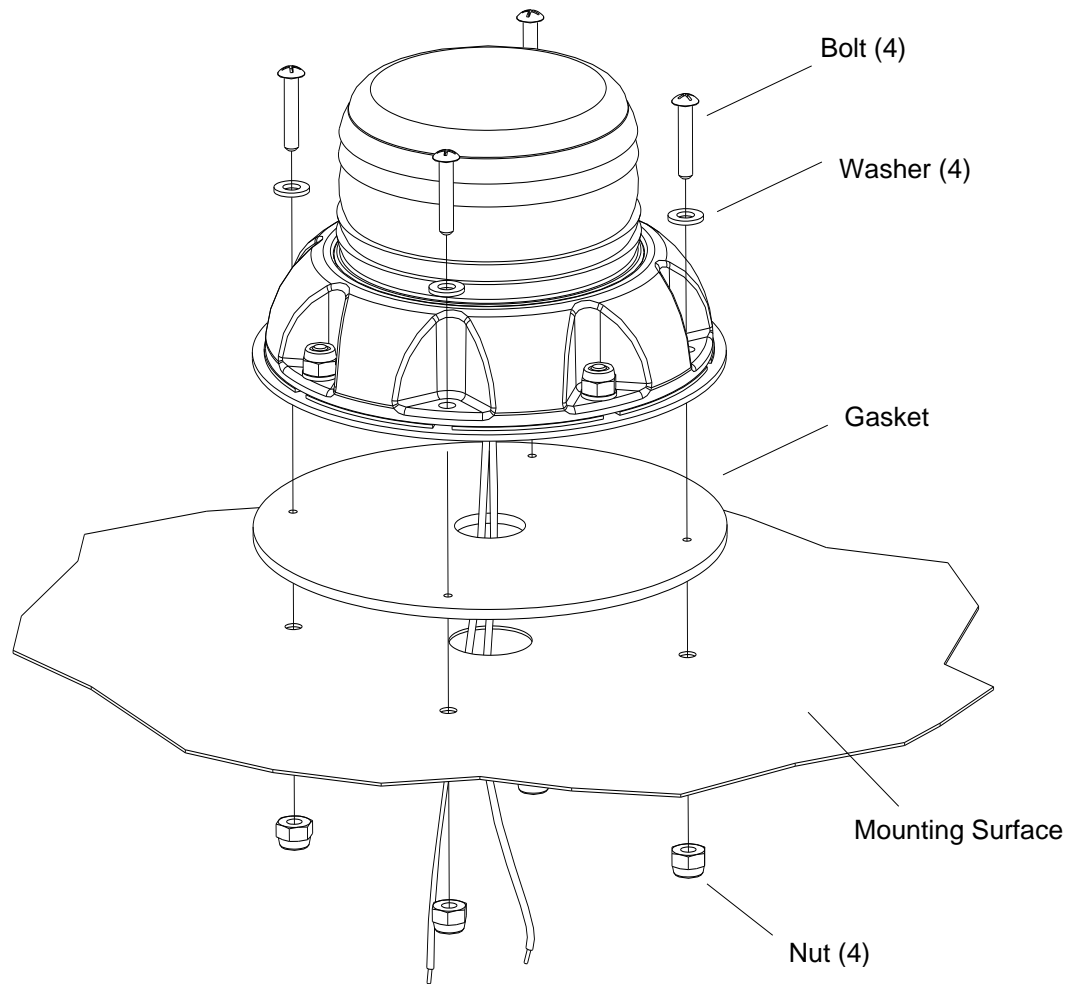

View C

Manufacturer Limited Warranty

The Manufacturer warrants that on the date of purchase, this product will conform to the Manufacturer's specifications for this product (which are available upon request). The Manufacturer further warrants that this product is free from defects in material and workmanship. This Limited Warranty extends for sixty (60) months from the date of manufacture (as evidenced on product label). The Manufacturer will, at its discretion, repair or replace any product found by the Manufacturer to be defective and subject to this Limited Warranty. Damage to parts or products resulting from tampering, accident, abuse or misuse, negligence, unapproved modifications, fire or other hazard, as well as improper installation, operation or maintenance voids this Limited Warranty.

Safe Fleet
13501 South Ridge Drive, Charlotte, NC 28273
Toll Free: 800-951-STOP (7867)
Phone: 704-247-9300
Fax: 980-216-4606
www.safefleet.net